

Water Leakage Location Detector  
AD-AS-1LCM-A  
Operation Manual

TATSUTA Electric Wire & Cable Co., Ltd.  
Electronics Division  
System Department

# <<<Important Safety Instructions!!>>>



## Warning

Erroneous operation of this water leakage detector not complying with the warning labels or the following warnings may not only lead to possible fatality or serious injury, but also fire, electric shock or failure.



## Warnings!



## Strict Prohibitions!

- Never modify or disassemble the detector.
- The staff not responsible for operation are forbidden to carry out the construction and the regular spot check.
- Do not touch any internal component of the detector with wet hands.
- When performing maintenance on the product, avoid using organic solvent. Use soft cotton wastes such as the gauze to wipe gently.



## Checkpoints!

- Check detector supply voltage and rated voltage before installing.
- When installing and electrically connecting the detector, follow the instructions in the instruction manual.
- When performing maintenance and periodical inspection on the detector, follow the instructions in the instruction manual.
- When using control output contacts, please check the rated loads of the contacts in the following detector specification.



## Do not install the detector in the following locations!

- Locations easily accessible to the general public.
- Locations close to sources of vibration, organic gas or strong electromagnetic induction.
- Locations with much waste and dust.
- Locations where there is possibility of water leakage and the temperature and humidity are high.

## Warranty

Before the delivery, this product is subjected to strict quality control and inspection. In the event of spontaneous failure resulting from defective manufacturing, we will repair or replace it according to the following provisions.

## Warranty Provisions

### 1. Warranty period (one year after the delivery date of the product)

Should the product fail during the warranty period under normal usage according to the operation manual, we will repair or replace it free of charge.

Please contact us using the contact information given below.

### 2. Cases not covered by the warranty:

After the period of warranty;

- Failures due to incorrect usage, and unauthorized repairs and modifications;
- Failures or damages due to moving, dropping etc. after the purchase;
- Failures or damages due to fire and natural disasters;
- Failures not attributable to this product;
- Fees for on-site service (visiting fee and technical fee).

## Consultation

Shanghai Representative Office: Room B28/F, Huadu Mansion, No.838 Zhang Yang Road, Pudong New Area, Shanghai, China, ZIP 200122

TATSUTA Electric Wire & Cable Co., Ltd.

Tel : 0086-21-5058-5177 Fax : 0086-21-5058-5199

Headquarter: ☎578-8585

2-3-1, Iwata-cho, Higashi-Osaka City, Osaka Prefecture

Tatsuta Electric Wire & Cable Co., Ltd. System Electronics Division

System Department System Division

Tel : 0081-6-6721-3335 Fax : 0081-6-6725-0018

Tokyo Branch: ☎210-0015

3rd floor, Nihon-Seimei Kawasaki Bldg., 1-1, Minami-machi,  
Kawasaki Ward, Kawasaki City, Kanagawa Prefecture

Tatsuta Electric Wire & Cable Co., Ltd. System Electronics Division

System Department, Sales Division

Tel : 0081-044-221-7691 Fax : 0081-44-221-7695

# Table of contents

	Page
1. Explanation of Individual Parts of Water Leakage Location Detector.....	1
2. Installation and Handling Precautions.....	1
2-1 Installation	
2-2 Handling Precautions	
3. Maintenance and Inspection .....	1
4. Configuration of Water Leakage Location Detecting System .....	2
5. External Connection .....	2-5
5-1 Power Connection	
5-2 Ground Connection	
5-3 Water Leakage Sensor Connection	
5-4 Control Output Contact Connection	
5-5 Water Leakage Location Data Output Connection	
5-5-1 Connection	
5-5-2 Abnormal Water Leakage Location Data Output	
6. Operation Check .....	6
6-1 Power-On	
6-2 Check for Break Detection Function	
6-3 Check for Water Leakage Detection Function	
7. Operation Chart.....	7-8
7-1 Standard Operation Chart	
7-2 Operation Chart When Alarm Hold Setting is Activated	
8. Indication of Detector Number .....	9
9. Detection Sensitivity Setting.....	9
10. Buzzer Setting .....	10
11. Specifications .....	10-11
11-1 Ratings	
11-2 Control Output Contact Specifications	
11-3 Performance	
◇ Attached Drawing 1 Outside Dimensions of Water Leakage Location Detector (AD-AS-1LCM-A)	
◇ Attached Drawing 2 Explanation of Individual Parts of Water Leakage Location Detector AD-AS-1LCM-A)	
◇ Attached Drawing 3 Explanation of Operational Setting Switches of Water Leakage Location Detector (AD-AS-1LCM-A)	
◇ Attached Drawing 4 Explanation-1 of Indicators of Water Leakage Location Detector (AD-AS-1LCM-A)	
◇ Attached Drawing 5 Explanation-2 of Indicators of Water Leakage Location Detector (AD-AS-1LCM-A)	

First of all, thank you very much for purchasing the Water Leakage Detector AD-AS-1LCM-A.

Before using, read this operation manual carefully to ensure correct operation. Keep this manual in a convenient place for quick reference.

## 1. Explanation of Individual Parts of Water Leakage Location Detector

Water leakage location detectors (AD-AS-1LCM-A) has functions in Drawing 1.

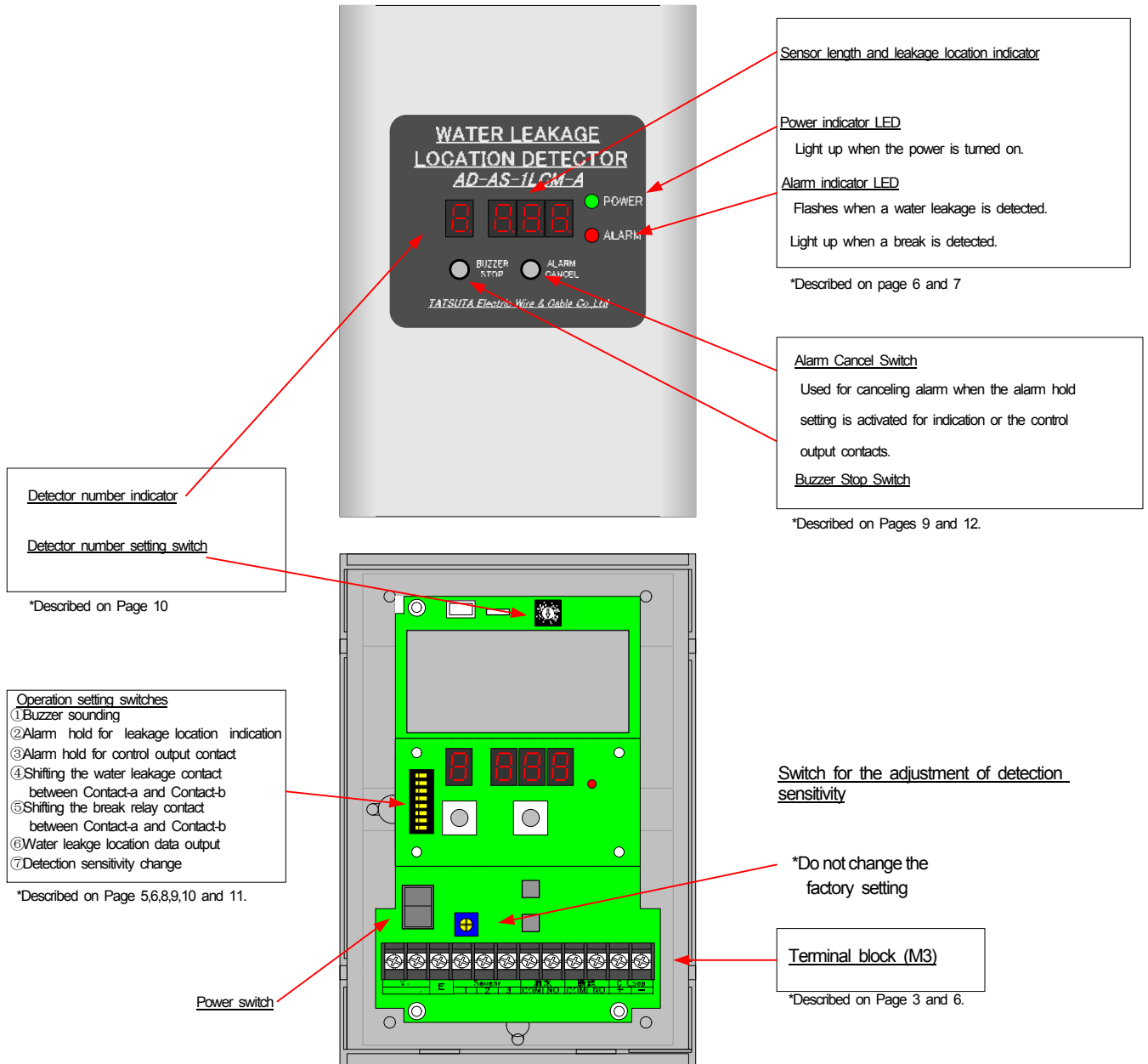

Drawing 1 Explanation of Individual Parts of Water Leakage Location Detector

## **2. Installation and Handling Precautions**

### **2-1 Installation**

The Water Leakage Position Detector (AD-AS-1LCM-A) shall be securely installed in a strong housing, on the wall, etc. inside a building.) Be sure to follow the instructions below when installing this product.

- 1) Avoid installing the detector in any location subject to high temperature and high humidity, excessively dusty environments and corrosive gas environments.
- 2) Install the detector in a location that is free from vibration, away from sources of interference such as power switches, and convenient for quick maintenance and regular inspection.
- 3) Install the inductive sensor using the suitable fixator, according to installation location and environment.
- 4) Consult with us in case the inductive sensor is used in places easy to be affected by electromagnetic induction.
- 5) Do not insert foreign matters, including screw-drivers into gaps in the detector.
- 6) Do not use the sensor as electric wire.
- 7) Never use inductive sensors other than our product AD-LS Sensor. This will cause serious errors in the location detection function. So pls make sure not to use or use together with any sensor other than AD-LS sensor.

### **2-2 Handling Precautions**

- 1) Use the detector in an environment with a temperature range between -10°C and 50°C and a humidity range between 35% to 85%.
- 2) Do not use the detector in any location close to sources of vibration and harmful gas, and strong electromagnetic inductive power sources.
- 3) After installation, be sure to apply the insulating sheet to the terminal block, and cover the surface cover plate, meanwhile confirm the operation.

## **3. Maintenance and Periodic Inspection**

When inspecting the facilities, conduct inspections in conformance with the operation check items described in Chapter 6.

Note) During inspection of the detector, the control output contacts are functioning, so if the control output contacts are used, disconnect the wiring or connect temporary wiring in order not to affect other devices.

- If the surface and inside of the sensor is adherent with water repellent substances like oil, normal operation is possible to be interfered. Please pay attention.
- If the sensor is tainted with dirty water, please replace it in time.

#### 4. Structure of Water Leakage Location Detecting System

The water leakage location detecting system consists of:

- ① Water leakage location detector (AD-AS-1LCM-A)
- ② Water leakage sensor (AD-LS)
- ③ Break detection terminal (ZT-L2)

For connections on the terminal block, refer to Attached Drawing 2.

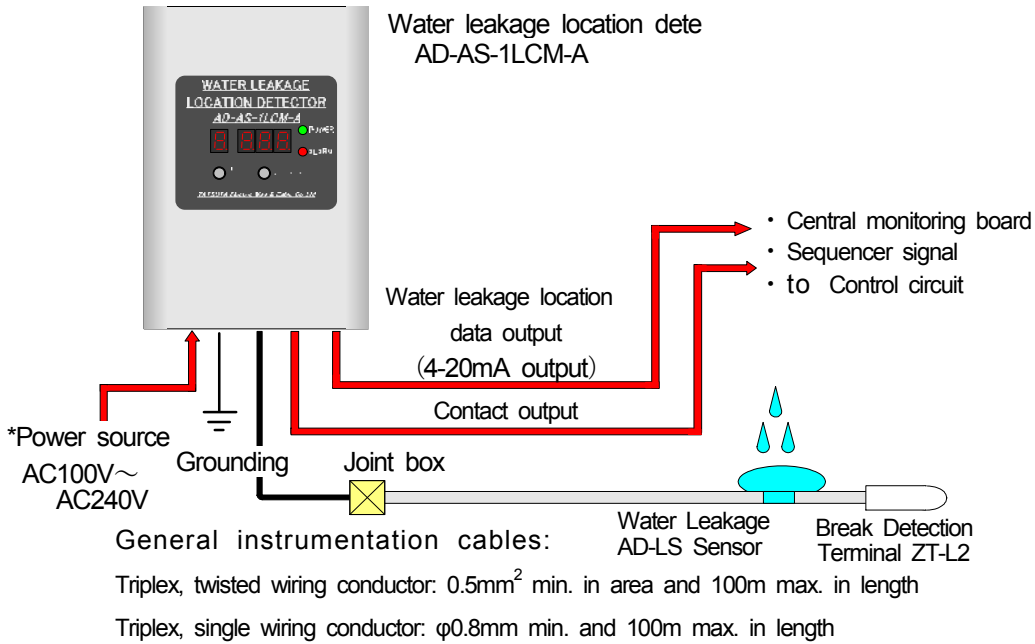

Drawing 2 Water Leakage Location Detecting System

#### 5. External Connection

AD-AS-1LCM-A has a terminal block as shown in Drawing 3. (Make connections securely in conformance to Sections 1 to 5.)

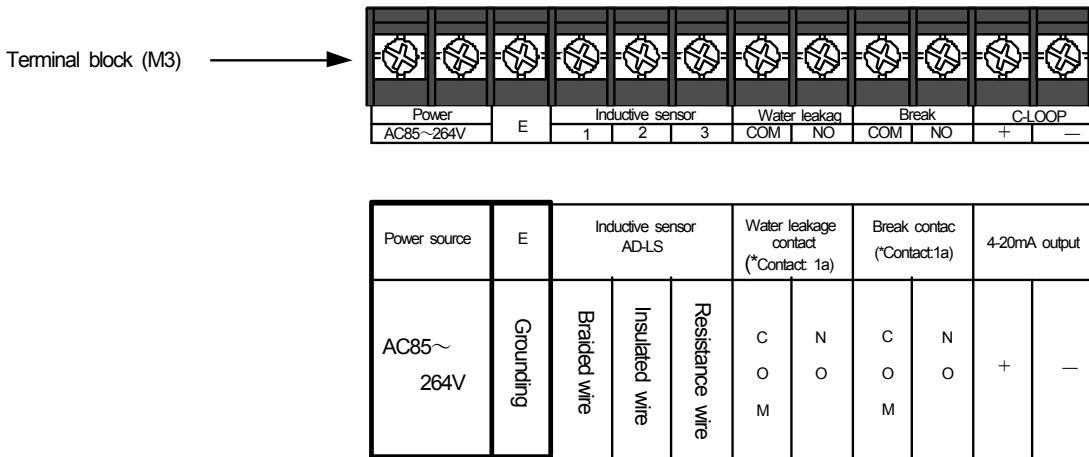

Drawing 3 Layout Drawing of Terminal Block

##### 5-1. Power Connection

AC100~240V (Variation range in power voltage: AC85~264V)

Before connection, check that the power supply voltage is within the range of use, then, connect it securely to the terminal block.

\*Inputting a power voltage outside the range of use may cause malfunctions and failure of the detector, so care should be taken.

##### 5-2 Ground Connection

Be sure to ground for interference prevention.

### 5-3 Sensor Connection

The structure of the Water Leakage Sensor (AD-LS Sensor) used for the Water Leakage Location Detector (AD-AS-1LCM-A) are shown in Drawing 4 and Table 4.

Shapes and functions of each wire vary, so care should be taken when connecting to the detector. Refer to Drawing 5

\*Incorrect wiring will result in inaccurate indication of water leakage locations or break alarm output.

\*While carrying out wiring, make sure that the power of the detector is switched off.

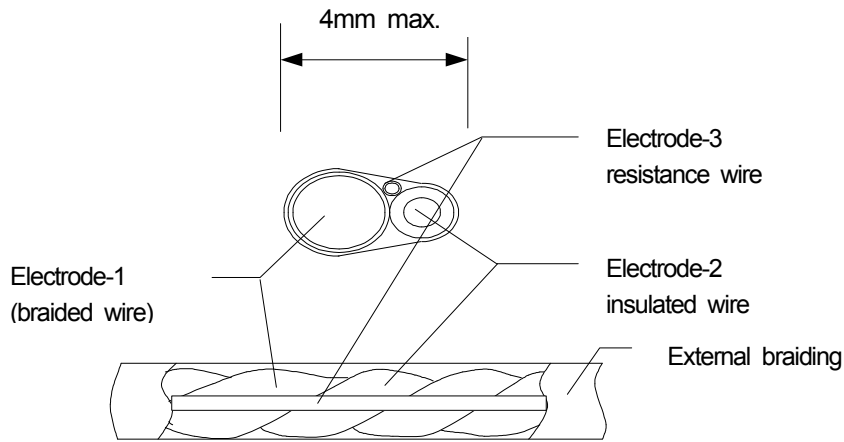

Drawing 4 AD-LS Sensor Structure

Table 1 AD-LS Sensor Configuration

Element	Configuration
Electrode 1	0.33-mm <sup>2</sup> tinned soft copper wire covered with red plastic braided thread
Electrode 2	0.5-mm <sup>2</sup> tinned soft copper wire insulated with green plastic
Electrode 3	φ0.4 resistance wire covered with white plastic braided thread
External braiding	White plastic braided thread

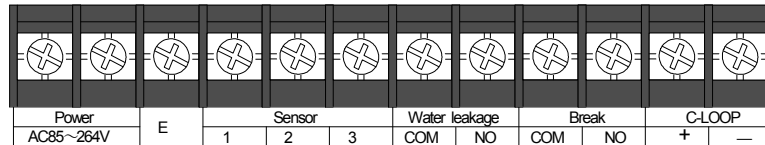

Power source	E	Sensor AD-LS			Water leakage contact (*Contact 1a)		Break contact (*Contact 1a)		4-20mA outp	
		Braided wire	Insulated wire	Resistance wire	C	N	C	N	+	-
AC85~ 264V	Grounding				C	N	C	N	+	-
					O	O	O	O		
					M		M			

Drawing 5 Terminal Block for Sensor Connection

5-4 Control Output Contact Connection

There are outputs for water leakage and break output connections (Contact a), use them if external control is needed. (Refer to Drawing 6.)

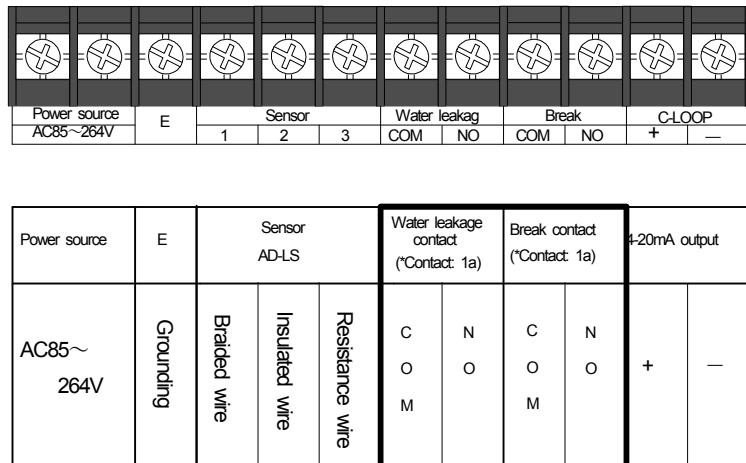

Drawing 6 Control Output Contact

Water leakage contacts COM-NO: Closed when water leakage is detected.

Break contacts COM-NO : Closed when a break is detected.

\* Contact operation

Changing operational setting switches shifts Contact a to Contact b. (Refer to Drawing 7.)

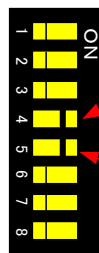

NO.4 ON ⇒ The water leakage Contact a is shifted to Contact b

NO.5 ON ⇒ The break Contact a is shifted to Contact b

Drawing 7 Setting for Water Leakage and Break Contact Operation

\*Alarm hold

Turning the Operation switch 3 ON activates the alarm hold setting.(Refer to Drawing 8.)

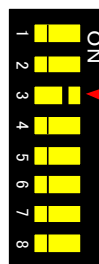

Turning no.3 switch ON ⇒ Alarm hold setting are activated for water leakage and break contacts.

Drawing 8 Alarm Hold Setting for Water Leakage and Break Contacts



## 5-5 Water Leakage Location Data Output Connection

### 5-5-1 Connection

The AD-AS-1LCM has a function that outputs the water leakage location by DC electrical current.

\*Use an analog input device with an input resistance of 500 Ω or lower.

Power		Sensor			Water leakage		Break		CLOOP	
AC85~264V	E	1	2	3	COM	NO	COM	NO	+	-

Power	E	Sensor AD-LS			Water leakage Contact (*Contact :1a)		Break contact (*Contact :1a)		4-20mA output	
AC85~264V	Grounding	Braided wire	Insulated wire	Resistance wire	C	N	C	N	+	-
					O	O	O	O		
					M	M	M	M		

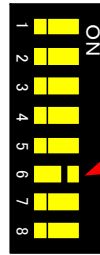

NO.6 ON => 4-20mA output setting change

Drawing 9 Water Leakage Location Data Output Connection

Drawing 10 Water Leakage Location Data Output Setting

### Output specifications

Normal sensor output current = 4 (mA)

Sensor output current in the case of sensor break detection = 20 (mA)

Output current in the case of water leakage detection =  $6 + 0.03 \times \text{water leakage location indication (m)}$  mA  $\pm 1\%$

\*Operation setting switches are used to change operations in water leakage detection.

Output current in the case of water leakage detection =  $16 \times \text{water leakage location indication (m)} / 250(\text{m}) + 4\text{mA} \pm 1\%$

### 5-5-2 Abnormal Water Leakage Location Data Output

In the case of abnormal water leakage location data output, an indication of “E01” is added on the 3-digit, 7-segment LED. (Refer to Drawing 11.)

This may result from the causes described below. Check the facilities.

Detector: Wiring connection among external analog input devices is broken or the input resistance for external analog input devices is more than 500Ω.

- The internal power inside the detector for

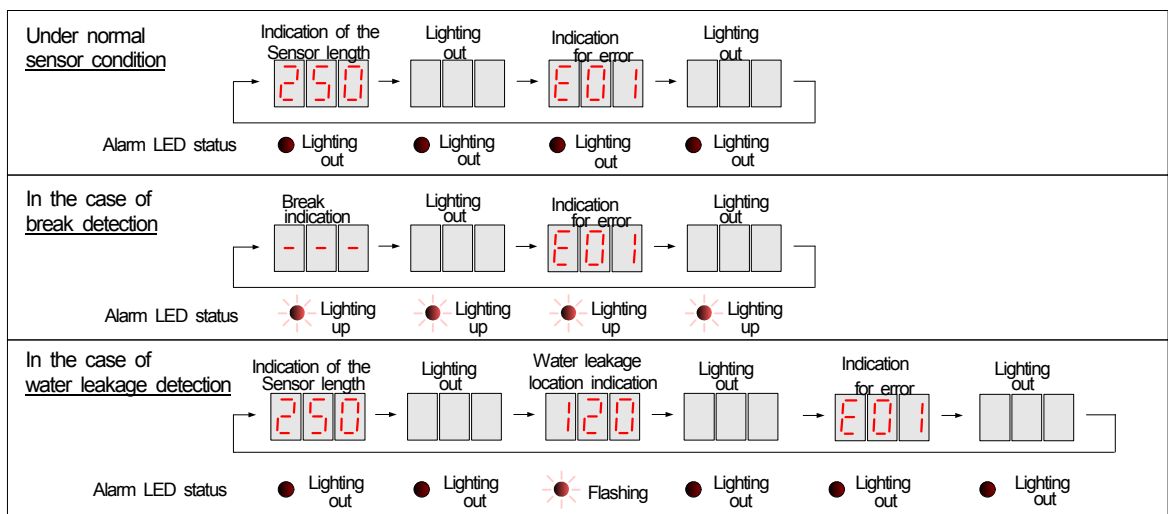

Drawing 11 Indications in the Case of Abnormal Water Leakage Location Data Output

## 6. Operation Check

### 6-1 Power-On

When the detector is powered on, the Power Indicator LED and the 7-segment LED light up. (Refer to Drawing 12.) In the case that the LED does not light up, the detector may be out of order. Power off the detector promptly and contact the manufacturer.

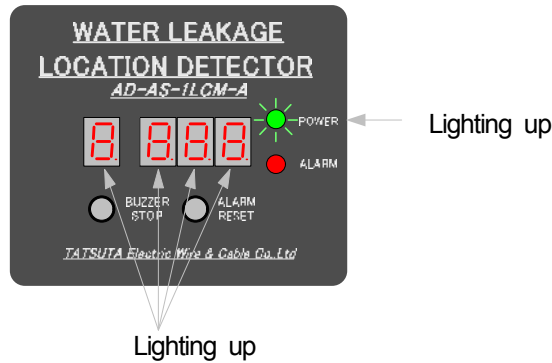

Drawing 12 Power-On Operation

### 6-2 Check for Break Detection Function

- 1) **After powering off the detector**, remove the water leakage sensor from the trunk terminal block and then power on the detector.
- 2) The buzzer sounds, the Alarm Indicator LED flashes and the contacts (for break detection) function.
- 3) The 3-digit, 7-segment LED indicates "—". (Refer to Drawing 13.)
- 4) After the operation check, **power off the detector** and then connect the sensor to the terminal block again.

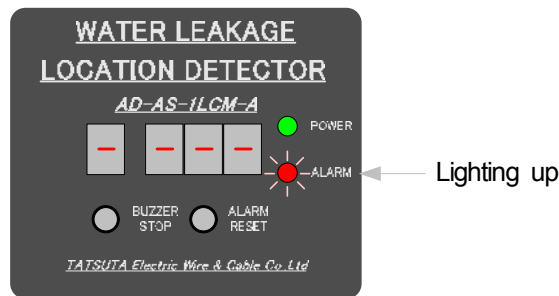

Drawing 13 Indication in the Case of Break Detection

### 6-3 Check for Water Leakage Detection Function

- 1) Drop tap water into the water leakage sensor.
- 2) The buzzer sounds, the Alarm Indicator LED lights up and the contacts (for water leakage detection) function.
- 3) The 7-segment LED indicates as shown in Drawing 14.  
Example: in the case in which a sensor with a length of 250 meters connected and a point at 120 meters wetted.
- 4) Wipe the tap water dropped on the sensor with dry rags, etc. and check that the water leakage status returns to normal.

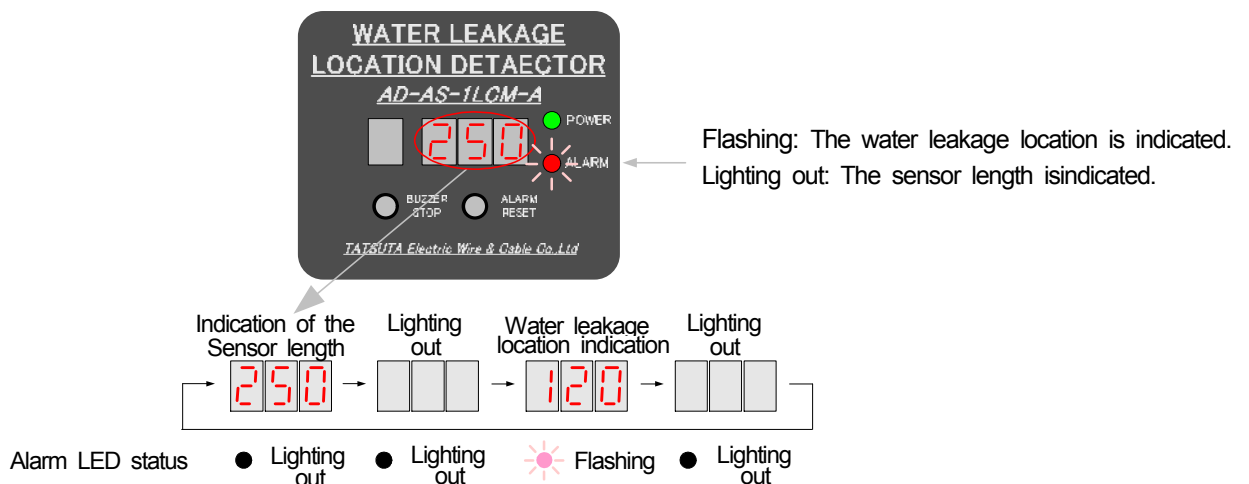

Drawing 14 Indication in the Case of Water Leakage Detection

## 7. Operation Chart

### 7-1 Standard Operation Chart

(Factory setting)

Refer to Drawing-15 for the operation chart.

Power	OFF	ON		
Power Indicator LED	Lighting out	Lighting up		
Water leakage detection function	OFF	ON	OFF	
Break detection function	OFF		ON	OFF
Alarm Indicator LED	Lighting out	Flashing	Lighting out	Lighting up
Buzzer Stop Switch	OFF		ON	OFF
Buzzer sounding	OFF	ON	OFF	ON
Control output contact (water leakage: COM-NO)	Open	Closed	Open	
Control output contact (break: COM-NO)	Open		Closed	Open
Sensor length indication	No indication	*1 Indication		Indicating —
Water leakage location indication	No indication	*1 Indication	No indication	
Water leakage location data output 4-20mA output	OFF	4mA	4mA	20mA

\*1 The sensor length and the water leakage location is indicated alternately. (See Attached Drawing-4)

### Drawing-15 Operation Chart-1

#### Buzzer

Pressing the buzzer stop switch stops the buzzer.

When the system detects another water leakage or a break, the buzzer sounds again.

Turning the No.1 operational setting switch ON to set the buzzer to constant sound. (Refer to Drawing 16)

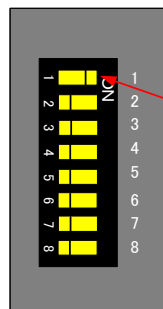

NO.1 ON ⇒ Sounding of buzzer is prevented.

Drawing-16 Buzzer Setting

### 7-2 Operation Chart When Alarm Hold Setting is Activated

Changing operational setting switches activates the alarm hold setting for indication and control output contacts.  
For the operation chart, refer to Drawing 18.

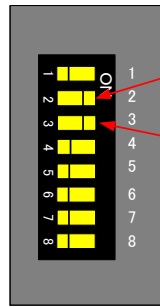

NO.2 ON ⇒ The condition is changed to that in which the alarm hold setting for the water leakage location indication is activated

NO.3 ON ⇒ The condition is changed to that in which the alarm hold setting for the control output contact is activated

Drawing 17 Alarm Hold Setting

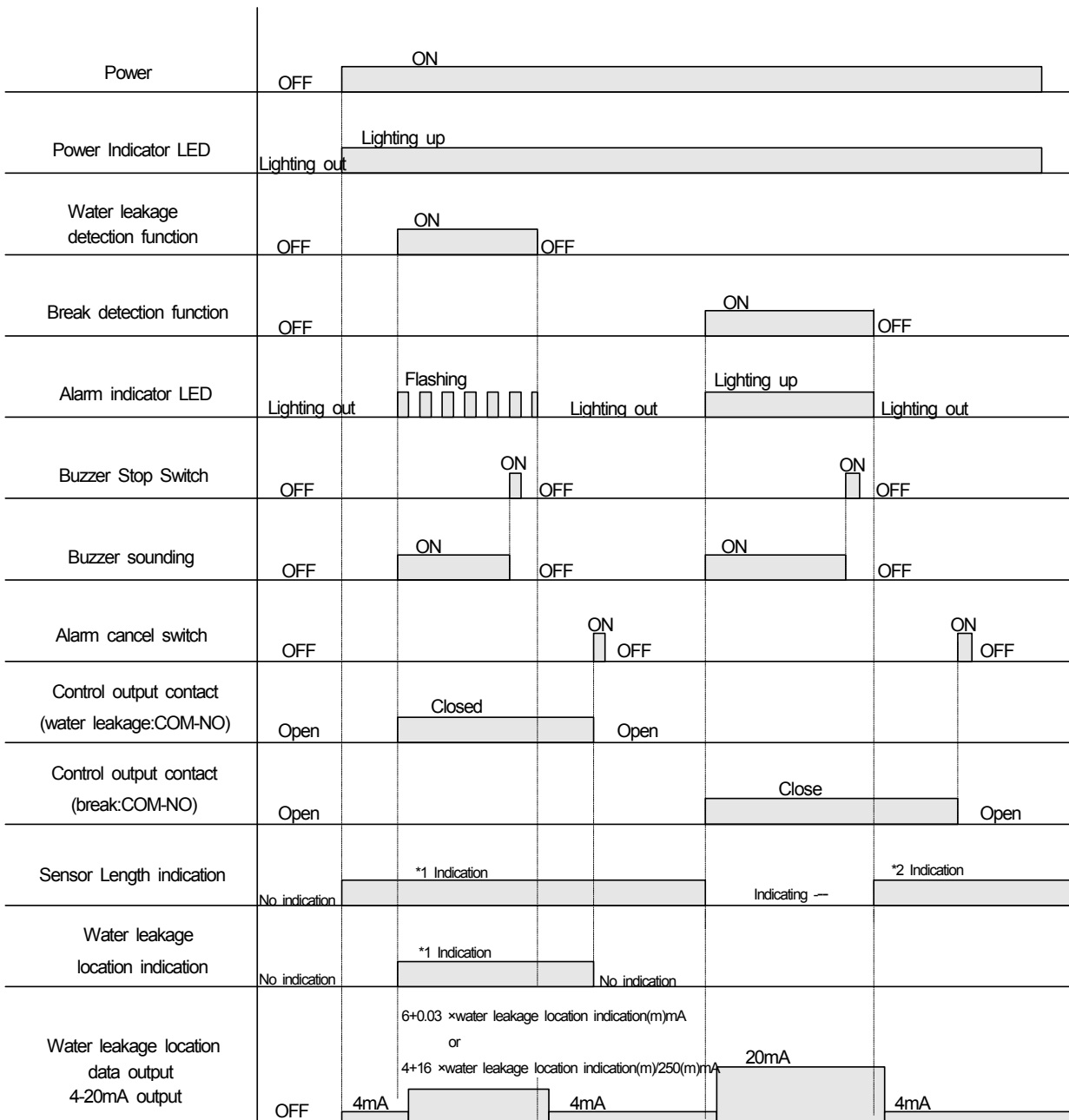

\*1 The sensor length and the water leakage location are indicated alternatively. (Refer to Attached Drawing 4)

\*2 For the break indication, the alarm status is not held.

Drawing 18 Operation Chart-1

### Regarding the operation when the alarm hold setting is activated

When the alarm hold setting is activated, the alarm status is held until the cancel switch is pressed.  
Electric power failure or power-off returns the contact operation status to that when the power source is shut off.  
When alarm holding is not set, refer to Drawing -15 and Operation Chart 1.

### Regarding the Alarm Indicator LED

The Alarm Indicator LED does not maintain alarm status. The Alarm Indicator LED goes out when the system detects recovery from water leakage status and break status.

If the Alarm Indicator LED continues to flash even after the water leakage sensor is wiped with rags etc., this indicates that water leakage may occur at multiple locations.

After completely drying the water leakage sensor at the location that the indicator displays, press the alarm cancel switch.

\* If drying is insufficient, deviation may occur between the water leakage location displayed after the alarm cancel switch is pressed and the actual water leakage location.

## 8. Indication of Detector Number

Related settings are necessary to be carried out if it is expected to indicate number on the indicator, in the case of multiple indicators are used together. Turn the Detector Number Setting Switch and select a number that you want to indicate. (Refer to Attached Drawing 19)

The detector number is indicated on the leftmost 7-segment LED.(1~9,A,B,C,D,E,F)

\*The factory setting is 0 (no indication).



Drawing 19 Indication of Detector Number

## 9. Detection Sensitivity Setting

Changing operational setting switches changes the detection sensitivity level. (Refer to Drawing 20.)

\*The water leakage sensor detects water leakage even it is caused by only a small amount of water (condensation, for example). Therefore, if the sensor is installed in a location subject to high temperature and high humidity, set the sensitivity level lower.

\* In the case in which it is necessary to detect fluid with high electrical resistance, such as pure water, in an environment where the temperature and humidity are stable, such as a clean room, it is recommended to set the sensitivity level high.

Factory setting

Standard sensitivity:  
approx.25kΩ

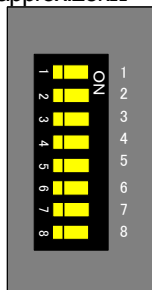

NO.7 ⇒ OFF  
NO.8 ⇒ OFF

Low sensitivity  
approx.10kΩ

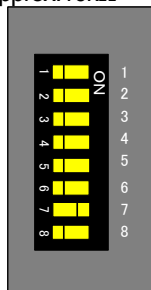

NO.7 ⇒ ON  
NO.8 ⇒ OFF

High sensitivity  
approx. 50kΩ

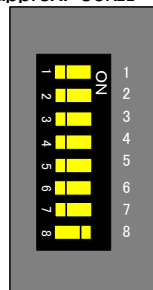

NO.7 ⇒ OFF  
NO.8 ⇒ ON

Highest sensitivity  
approx. 100kΩ

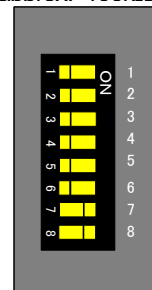

NO.7 ⇒ ON  
NO.8 ⇒ ON

Drawing-20. Detection Sensitivity Setting

## 10. Buzzer Setting

Turning the No.1 operational setting switch ON to set the buzzer to constant sound. (Refer to Attached Drawing 21.)

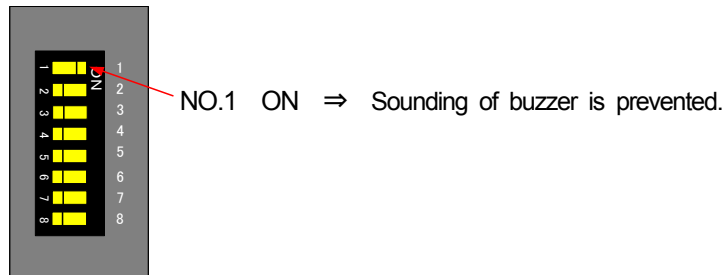

Drawing-21. Buzzer Setting

## 11. Specifications

### 11-1. Ratings

For ratings, see Table 2.

Table 2 Ratings

Item	Specifications
Rated voltage	AC100~240V
Supply voltage fluctuation	AC85~264V
Power consumption	5W max.
Control output grounding	*Check Subsection 11-2, control output contact specifications.
Sensor applied voltage	AC5. 5V max.
Working ambient temperature	0°C to 50°C (no icing)
Working ambient humidity	35%RH to 85%RH (no condensation)

### 11-2 Control output contact specifications

For control output contacts, refer to Table 3.

Table 3 Control Output Contact Specifications

Item	Resistance load	Inductive load
Rated load	AC125V 0. 4A	AC125V 0. 2A
	DC 30V 2. 0A	DC 30V 1. 0A
Minimum load	DC10mV 10μA (reference value)	

(Relay contact: G6E-134P-US Sample values by OMRON Corporation)

### 11-3 Performances

For performance parameters, refer to Table-4.

Table 4 Performances

Item	Specifications			
Number of sensor circuits	1			
Length of sensor connection	1 to 250m			
Detecting sensitivity level setting	Low	Standard	High	Highest
Water leakage detection sensitivity	10kΩ±20%	25kΩ±20%	50kΩ±20%	100kΩ±20%
Sensitivity in the case of recovery from water leakage	16kΩ±20%	37kΩ±20%	68kΩ±20%	125kΩ±20%
Detecting accuracy	1~100m : ±1m 101~250m : Sensor length ± 1%			
Surface panel operation switch function	Buzzer stop switch: 1			
	Alarm cancel switch: 1			
Surface panel LED indication	Power source indication, green: 1 (lighting up)			
	Alarm indication, red: 1 (flashing in the case of water leakage detection) (lighting up in the case of break detection)			
Surface panel 7-segment LED indication	Detector number indication: 1 digit (1 to 9, A, b, C, d, E and F) Sensor length and water leakage location indication: 3 digits, in meters			
Surface panel operation setting switch	Used for setting change of indication, control output contacts, detection sensitivity level, etc.			
Buzzer	Average sound pressure: 90 dB/10 cm (sample value by manufacturer)			
Control output contact	Contact Configuration	◇ Contacts (For specifications, refer to Section 3-3.)		
		Water leakage: 1 for 1a Break: 1 for 1a * Setting change of the operation switches shifts to Contact b.		
Water leakage location data output	4~20 mA current loop output (external load resistance: 500 Ω max.) x 1 Under normal sensor conditions: 4 mA In the case of sensor break detection: 20 mA In the case of water leakage detection: 6 + 0.03 x water leakage location indication (m) mA ± 1% * Changing operational setting switches changes operation in the case of water leakage detection. (Refer to Attached Drawing 3.) In the case of water leakage detection : 16 x water leakage location indication (m) / 250 (m) + 4 mA ± 1%			
Withstand voltage	AC 1500V (50/60 Hz)/1 minute (between the power source terminal and the body case)			
Insulation resistance	10 MΩ min. (with DC 500V Megger)/1 minute (between the power source terminal and the body case)			
Noiseproofing property	±500V Pulse width: 1 μSEC (noise simulator)/1 minute (between each phase and the grounding terminal)			
Outside dimensions	W106 x H95 x D61 (unit: mm) (Refer to Attached Drawing 1.)			
Weight and color	Approx. 300 g, grey			

Attached Drawing-1

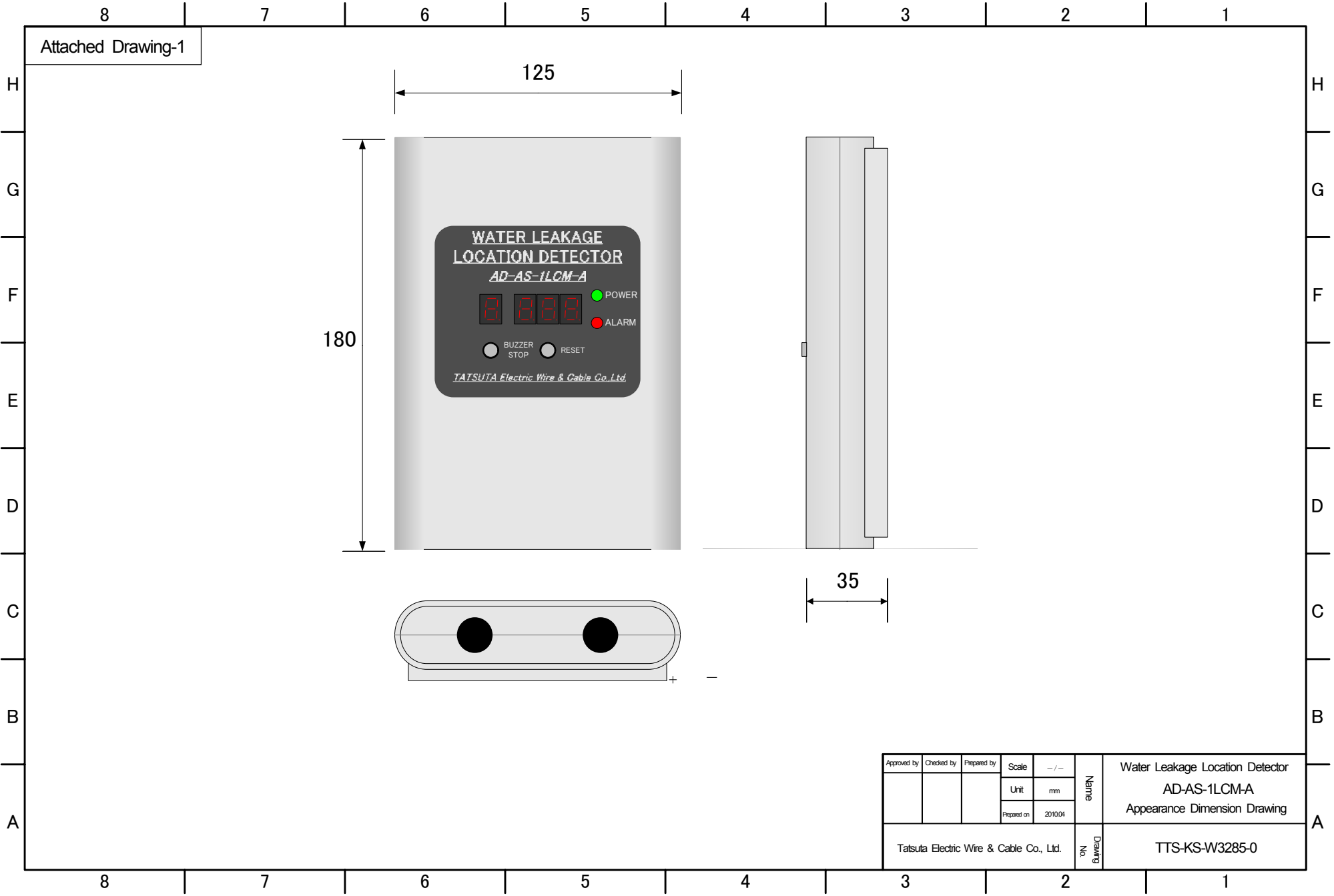

Approved by	Checked by	Prepared by	Scale	-/-	Name	Water Leakage Location Detector AD-AS-1LCM-A Appearance Dimension Drawing
			Unit	mm		
			Prepared on	2010/04		
Tatsuta Electric Wire & Cable Co., Ltd.					Drawing No.	TTS-KS-W3285-0



Attached Drawing-2

- Detector number setting switch
- Operation setting switch
- Detection sensitivity adjustment switch
- \*Do not change factory setting
- Power switch
- Terminal block(M3)

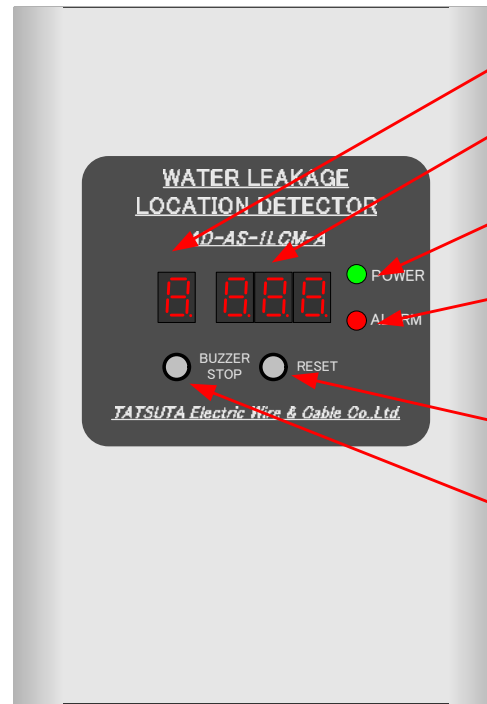
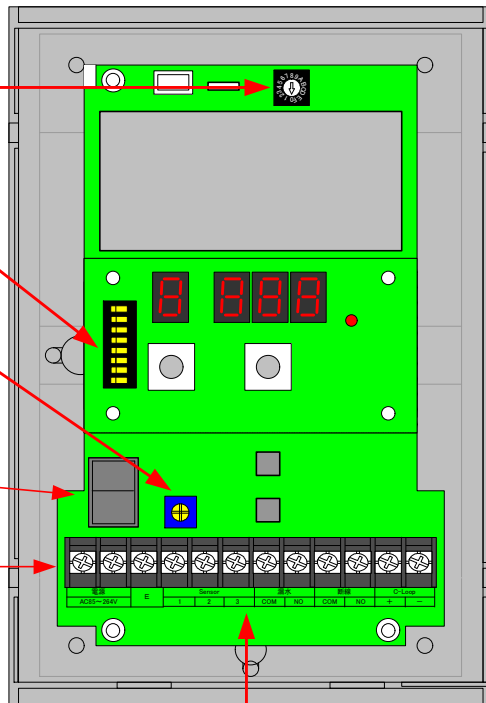

- Detector number indication
- Sensor length and water leakage indication
- Power source indication LED
- Alarm indication LED
- Alarm cancel switch
- Buzzer stop switch

Power	E	Sensor AD-LS			Water leakage contact (*Contact: 1a)		Break contact (*Contact: 1a)		4-20mA output	
AC85V~ AC264V	Grounding	Braided wire	Insulated wire	Insulated wire	C O M	N O	C O M	N O	+	-

Approved by	Checked by	Prepared by	Scale	--/--	Name	Explanation of various parts of the Water Leakage Location Detector AD-AS-1LCM-A
			Unit	mm		
			Prepared on	2010.04		
Tatsuta Electric Wire & Cable Co., Ltd.					Drawing No.	TTS-KS-W3286-0

Attached Drawing-3

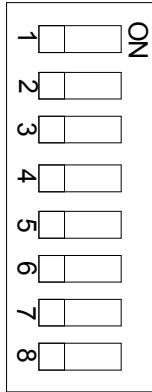

No	Factory setting	Operation
1	OFF	Buzzer sound OFF : Activated ON : Not activated
2	OFF	Alarm hold for water leakage location indication OFF : Not activated ON : Activated
3	OFF	Alarm hold for water leakage and break relays OFF : Not activated ON : Activated
4	OFF	Operation between Contact a and Contact b for water leakage relay OFF : Contact a ON : Contact b
5	OFF	Operation between Contact a and Contact b for break relay OFF : Contact a ON : Contact b
6	OFF	4-20mA operation OFF in the case of water leakage detection: $6+0.03 \times \text{water leakage location indication (m) mA}$ Ex: Water leakage is located at 100m : $6+0.03 \times 100 = 9\text{mA}$ ON in the case of water leakage detection: $4+16 \times \text{water leakage location indication (m)/250 mA}$ Ex: Water leakage is located at 100m : $4+16 \times 100/250 = 10.4\text{mA}$
7	OFF	Detection sensitivity shifting (7) (8) OFF - OFF Standard sensitivity    Approx. 25kΩ ON - OFF Low sensitivity    Approx. 10kΩ
8	OFF	OFF - ON High sensitivity    Approx. 50kΩ ON - ON Highest sensitivity    Approx. 100kΩ

\*Changing setting of switches correspondingly change operations such as indication and relay.  
 If it is changed to no function status, no corresponding operation is activated, so care should be taken.

Approved by	Checked by	Prepared by	Scale	— / —	Name	Water Leakage Location Detector AD-AS-1LCM-A Operation setting switch instructions
			Unit	mm		
			Prepared on	2010.04		
Tatsuta Electric Wire & Cable Co., Ltd.					Drawing No.	TTS-KS-W3287-0

Attached Drawing-4

**Indication under normal sensor conditions**



**Indication in the case of break detection**

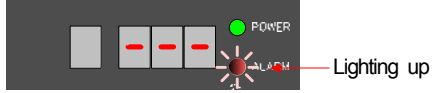

**Indication in the case of water leakage detection**

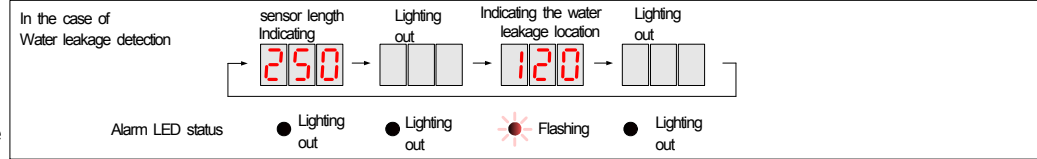

**Indication for abnormal water leakage data output**



In the following cases, an indication of "E01" is added:

- ① Detector: Wiring connection between external analog input devices is broken, or the input resistance for the external analog input devices is more than 500Ω.
- ② The internal power source inside the detector for 4-20mA output is out of order.

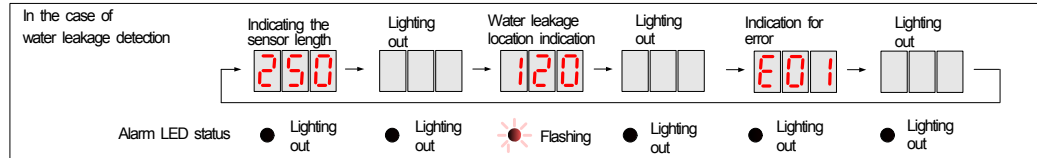
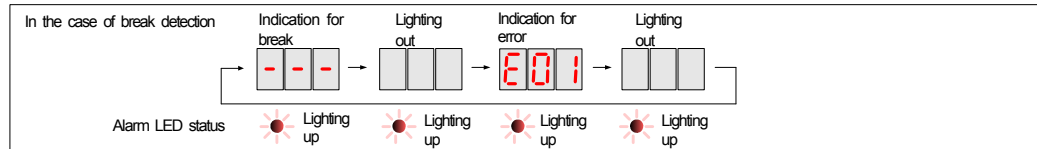
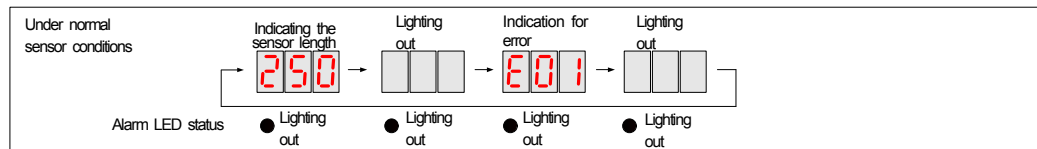

Approved by	Checked by	Prepared by	Scale	— / —	Name	Water Leakage Location Detector AD-AS-1LCM-A Indication instruction-1
			Unit	mm		
			Prepared on	2010.04		
Tatsuta Electric Wire & Cable Co., Ltd.					Drawing No.	TTS-KS-W3288-0

Attached Drawing-5

Detector Number Indication

Detector Number Indication

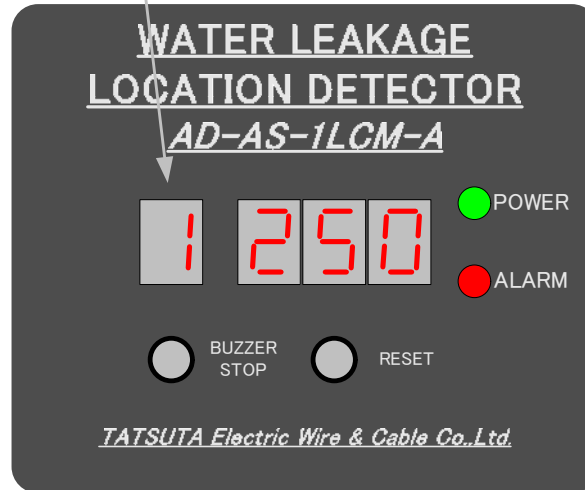

Detector number setting switch

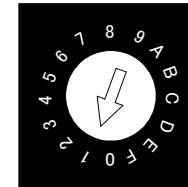

Use this function in the case it is necessary to indicate the number of each detector, when multiple detectors are used together.  
 Turn the Detector Number Setting Switch to select a number that you want to indicate.  
 The detector number is indicated on the leftmost 7-segment LED. (1 to 9 and A, B, C, D, E, F can be indicated.)  
 \*The factory setting is 0 (no indication).

Approved by	Checked by	Prepared by	Scale	— / —	Name Water Leakage Location Detector AD-AS-1LCM-A Indication instruction-2	
			Unit	mm		
			Prepared on	2010.04		
Tatsuta Electric Wire & Cable Co., Ltd.					Drawing No.	TTS-KS-W3289-0